

LIBERTY

Wall mounted European internal thermostatic trim
Facade thermostatique murale et section du meme
Ref # 1111385

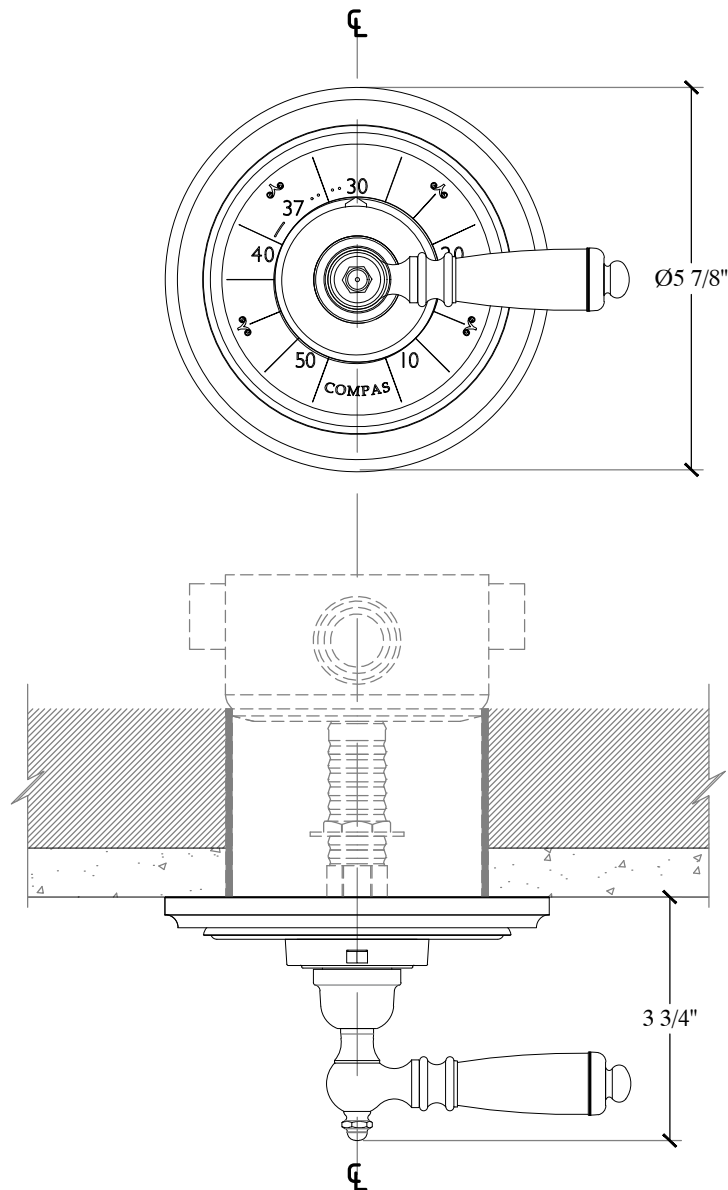

Copyright © Compas 2010 www.compasstone.com

COMPAS

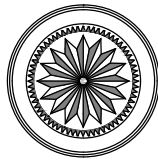

IN - WALL THERMOSTATIC SYSTEM

Standard In-wall thermostatic technical specs F $\frac{3}{4}$ " NPT
Anti - Scalding configuration system integrated
Mitigeur thermostatique a escaster - F $\frac{3}{4}$ " NPT
Weight: 3.75 lbs
Ref # 0006656

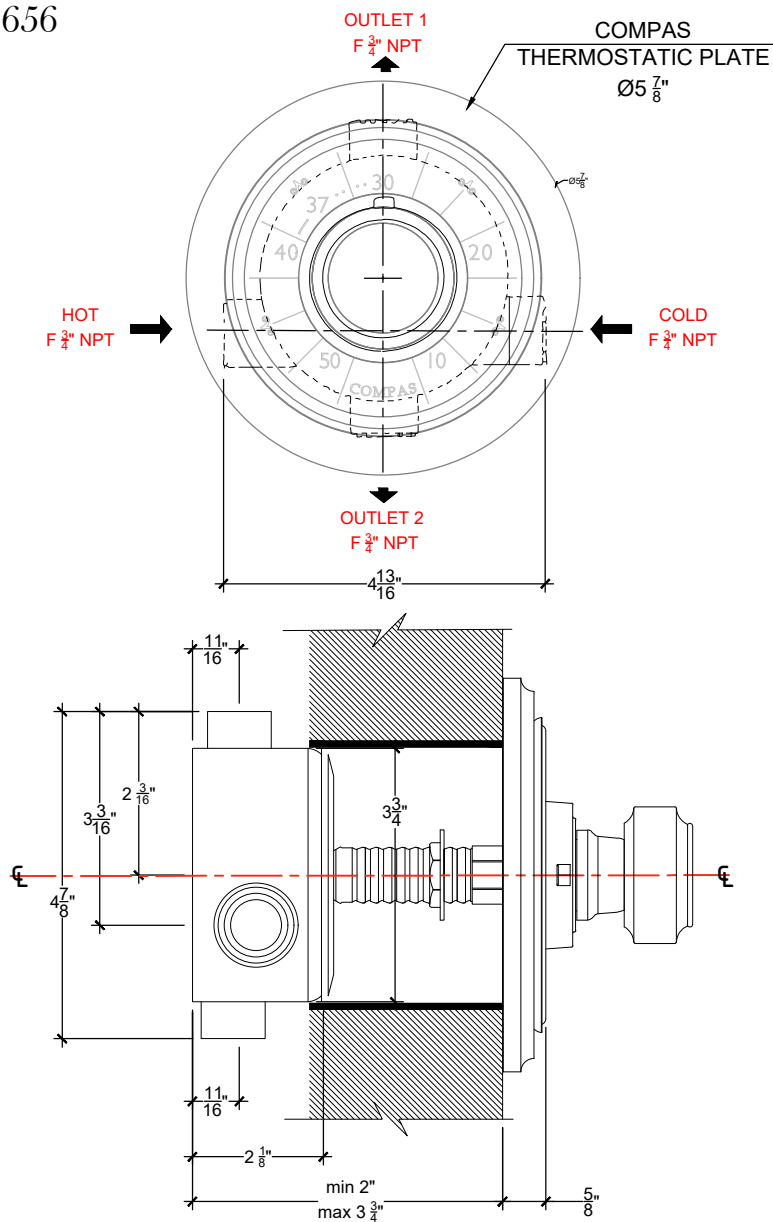

Copyright © Compas 2010 www.compasstone.com

 COMPAS™

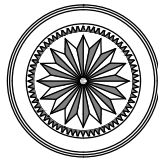

IN - WALL THERMOSTATIC SYSTEM

Standard In-wall thermostatic technical specs F 3/4" NPT

Anti - Scalding configuration system integrated

Mitigeur thermostatique a escaster - F 3/4" NPT

Weight: 3.75 lbs

Ref # 0006656

FLOWS UNDER 3 BAR DYNAMIC

M o d e l	8280	
	upper outlet (1)	lower outlet (2)
Flow l/min	80	60
Flow l/sec	1,33	1

PRESSURE

* OPERATING PSI

RECOMMENDED PSI = 58

MIN. 15 PSI / MAX 145 PSI

DEBIT in G/min

20 G/min@ 3 BAR

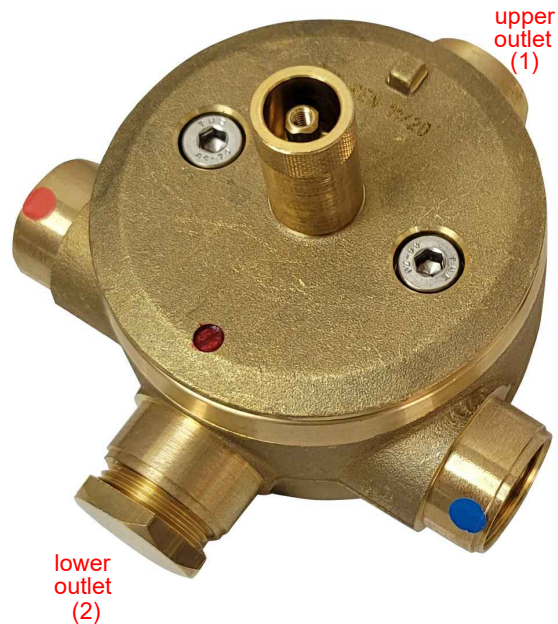

Copyright © Compas 2010 www.compasstone.com

 COMPAS™